

CONTENTS

	<u>PAGE</u>
Chapter One Apprenticeship_____	1
Chapter Two Electrician_____	9
Chapter Three Education_____	29
Chapter Four Women _____	55
Chapter Five License _____	69
Chapter Six Inspection_____	96
Chapter Seven Torque _____	116
Chapter Eight Load Test _____	138
Chapter Nine Circuit Analyzer _____	153
Chapter Ten Safety _____	162
Conclusion _____	185

Introduction

Imagine: As in the days gone by, the prime instinct of almost any child is to make and create. They will make things of materials as they have at hand, and use the force of dream and fancy to create something out of nothing. Example: They put several wooden blocks together with a spool on one end and call it a train. They have created an engine, which they see but which you don't, for the blocks and spool are only a symbol of their creation. They may use a broom for a horse, tin cans with a string between them for a phone.

As soon as the mystery of this modern day wonder firmly grips your imagination, you may come to realize that we are living more and more in the age of electricity.

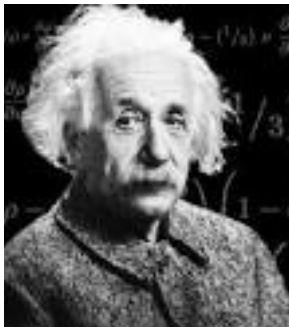

Albert Einstein

"Imagination is more important than knowledge. For knowledge is limited, whereas imagination embraces the entire world, stimulating progress, giving birth to evolution."

There is no better education for any person than to begin at the bottom of the ladder and climb the rungs of scientific knowledge, step by step. To the person interested in science, a wide field is open.



The world turns at the end of a wire, with electricity and electrical apparatus.

New developments in science will never cease. Invention will follow invention. The unexpected is often a valuable clue. The Edisons and Teslas have not discovered everything.

I first became interested in electricity when as a child I went down into the basement and pulled the string for the light and nothing happened. I pulled it several times with the same result. I then carefully unscrewed the bulb and looked at it to see if it was damaged. I then put my finger into the socket to see if something was wrong with it. I then pulled the string. After I picked myself up from the floor, I realized that the bulb must be burned out. I quickly realized that electricity is a powerful force. Even today I remember the time I pulled that string on that light and shook hands with God.

Apprenticeship

The formal system of training a new generation of skilled craft or trade practitioners, which is still popular in some countries, is called an apprenticeship. Apprentices build their careers through structured, formal apprenticeship training. Most of their training is done on the job, balanced with classroom studies, while working for an employer who helps the apprentices learn their trade. The system of apprenticeship was developed in the later Middle Ages (14th and 15th centuries) and came to be supervised by craft guilds and town governments.



A master craftsman was entitled to employ young people in his workshop as an inexpensive form of labor in exchange for providing formal training in the craft. Apprentices were usually about 14 to 21 years old, unmarried, and **would live with the master craftsman's family.**

Most apprentices aspired to becoming master craftsmen themselves upon completion of their contract (**usually seven years**). Upon completion of the apprenticeship, they would work as a journeyman but a significant number would never achieve the status of master craftsman or acquire their own workshop. During the 20th century, the apprenticeship process has changed in many ways. A craftworker or tradesperson still begins as an apprentice, but the apprenticeship is carried out partly through working with a qualified journeyman and partly through an accredited trade school for a definite period of time (usually around four years), after which they are a fully qualified journeyman.



“Craftsmanship” results when highly trained, skilled, and knowledgeable workers use tools and machinery to perform their work, or trade, with the highest levels of quality and appeal. But this “craftsmanship” and pride in workmanship is nothing new. Artisans were the predominant producer of goods in the era before the late 18th century Industrial Revolution and were the predecessors of the “craftsman.” Artisans, and later craftsmen, were revered in their knowledge and abilities to build, create, or construct their products with high degrees of excellence.

Centuries ago, craftsmen were admired and highly sought after.

The Electrical License Exam Information

I have been involved with electrical exams since 1969 and I would like to share with you some of the history and how the formats have changed.

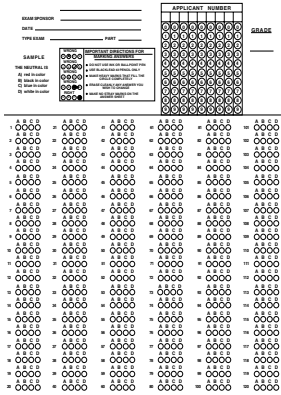

Over the years, I have seen the electrical exam change from the personal graded psychomotive (hands-on) testing to the **cognitive** (factual knowledge) computer graded exam.

Exams during this era were also more psychomotive (hands on) which required a person to personally grade the applicant in their skills of bending conduit, connecting control circuits, parts identification boards, etc. Cost was the reason given to eliminate the hands-on personal testing in favor of the computer or machine grading.

I strongly believe in permits, inspections and licensing. Most of all I believe in *education* and continuing education in the electrical trade and providing to society a *reputable qualified electrician*.

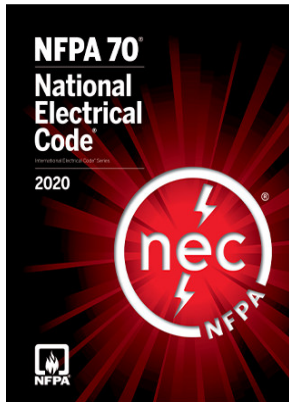

The National Electric Code, NEC is written to ensure “safety” in the electrical industry. Specifically, it is the “minimum” safety manual. The NEC's goal is to provide the practical safeguarding of persons and property from hazards arising from the use of electricity through provisions that are considered necessary for safety. It has also been said by an English professor that the NEC was written at the level of a second-year college student of English. Reading it alone is not practical. It must be taught and explained.

What must be understood with testing is the electrical industry has specialized categories just as the medical field has. You have a doctor who is a specialist for eyes, kidneys, bones, etc. It's the same situation in the electrical industry. We have electricians in construction wiring, service work, maintenance, inspection, designing, engineering, etc. The electrical exam may ask questions from a category you are not familiar with so one must properly prepare in all categories to enhance passing the electrical exam.

NORMAL CONDITION 240 VOLTS

The sketch below is a 50 amp circuit breaker 240v, 5.56 ohm load #4 aluminum wire with no neutral conductor. The normal current flow at full load would be: $I = E \div R = 240v \div 5.56\Omega = 43.2$ amperes.

TRANSFORMER 240V

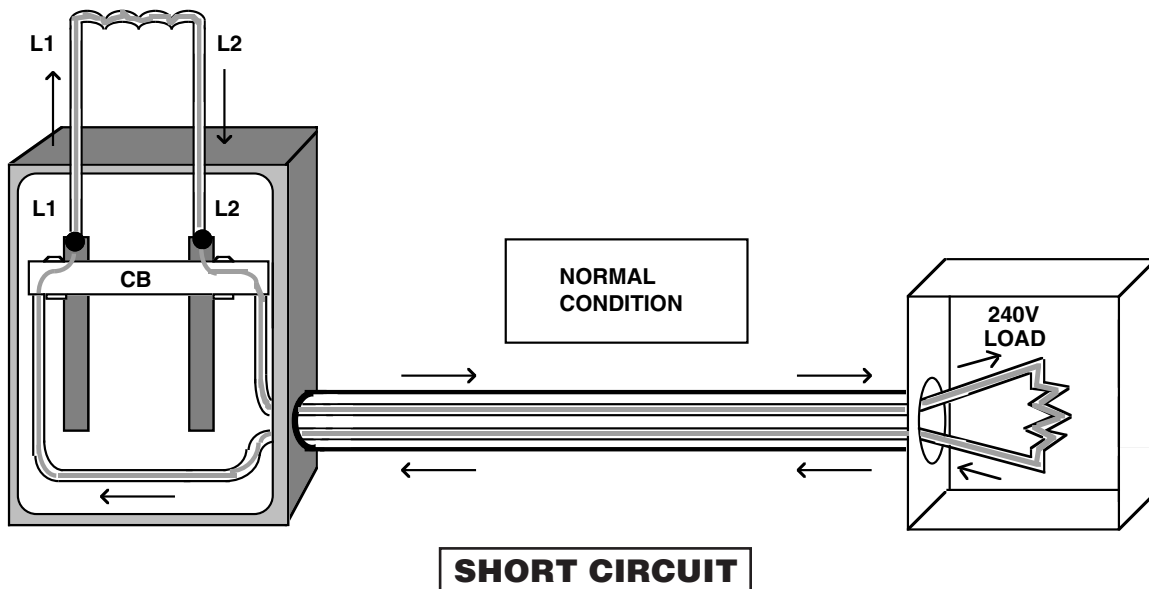

The sketch below shows a short-circuit which eliminates the 5.56Ω load in the circuit. If the short-circuit occurred 50 feet from the source the resistance of 100 feet of #4 aluminum wire would be $.508\Omega$ per m/ft $\times .100' = .0508\Omega$. $I = E \div R = 240v \div .0508\Omega = 4724$ amperes of current flowing. If #6 aluminum were used, the current flow would be $240v \div .0808\Omega = 2970$ amperes. If #8 aluminum were used the current flow would be $240v \div .128\Omega = 1875$ amperes. You can see how resistance affects the fault current flow in a conductor. The missing neutral conductor plays no part in this short-circuit.

